



Digital Security Screening System

**SECURPASS**

Complete Personnel Security Portal

Detect, Recognize &  
Secure in **8 Seconds**



## Maximize Security / Minimize Physical Searches

Low dose X-ray scanning system that detects all types of dangerous or illegal substances such as liquid explosives, drugs, copper wires, plastics, etc. Based on unique patented technology, SECURPASS is capable of handling the high level security needs at airports, prisons, border crossings and government buildings.

## FEATURES / SPECIFICATIONS

- Quicker / consistent checkpoint passage (2x)
- Detect dangerous metallic and non-metallic items
- Maximize security and minimize the need for physical searches
- Passenger friendly inspection of shoes/clothing without removal
- Radical low radiation dosage for single inspection
- Inspection privacy: system does not reveal skin surface or fine anatomical detail

### ■ APPLICATIONS

- **Civil Security:** airports, seaports, railways, bus stations
- **Border Security:** customs, police
- **Prison Security:** guards, prisoners, visitors, staff
- **High Level Security:** nuclear power plants, military premises, embassies, etc

### ■ GENERAL

Scan Area	81.9 x 29.1 in (208 x 74 cm)
Scanning Time	under 8 seconds
Penetration (steel)	1.18 in (30 mm)

### ■ RESOLUTION

Spatial	30 AWG (0.25 mm)
---------	------------------

### ■ GENERATOR

Configuration	Monoblock oil cooled design
Anode Voltage	150 kV

### ■ DOSE / INSPECTION

Screening Model (4,000/y/subject)	< 0.25 uSv (0.025 mR) / per scan
High Penetration Model (500/y/subject)	< 2.0 uSv (0.2 mR) / per scan

### ■ IMAGING SYSTEM

Monitor	22" monitor
Grayscale	16,384 (image)
Local Storage	40,000 images
Image Visualization Time	Real Time
Power	220 V / 110 V, 50 Hz / 60 Hz, 2 kW

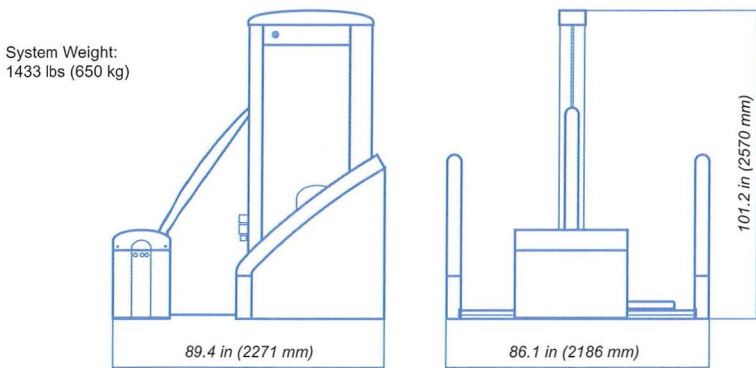

## Personnel Security Screening System

Low dose X-ray scanning system that detects all types of dangerous or illegal substances such as liquid explosives, drugs, copper wires, plastics, etc. Based on unique patented technology, **SECURPASS** is capable of handling the high level security needs at airports, prisons, border crossings and government buildings.

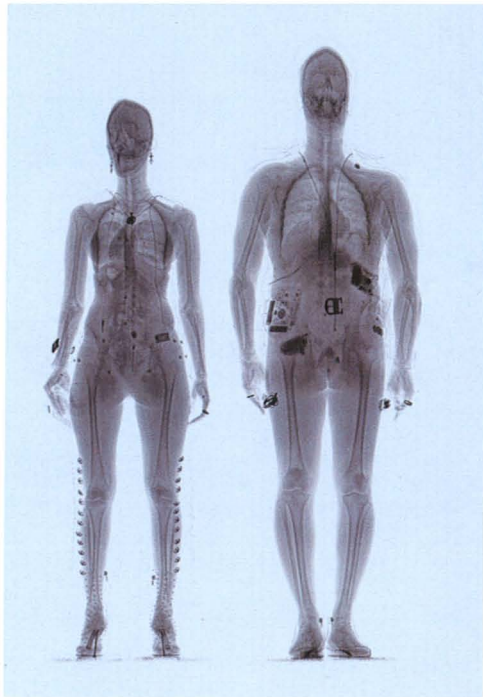

**SECURPASS** is able to image prosthetics to identify hidden narcotics, weapons, contraband, etc. (*Make-up, Medication, Personal Items, Special Needs Items, Electronic Devices, Sharp Objects, Sporting Goods, Guns/Firearms, Tools, Martial Arts/Self Defense Items, Explosive/Flammable Materials, Disabling Chemicals, Food/Drinks*) and any objects that could be considered as dangerous.

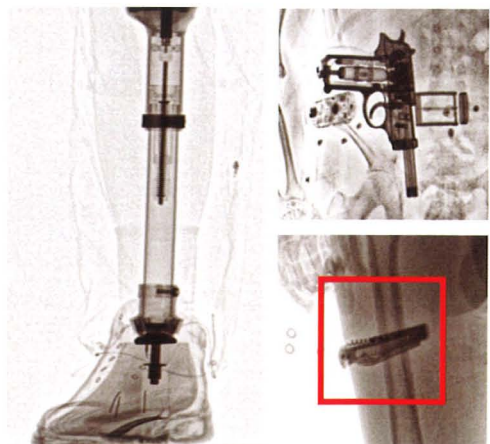

**Canon**

### VIRTUAL IMAGING, INC.

A Canon U.S.A. Company  
720 S. Powerline Rd, Suite E, Deerfield Beach, FL 33442  
PH: (800) 428-6191, (954) 428-6191 FX: (954) 428-6195  
www.virtualimaging-fl.com

Specifications are subject to change without notice. Names of companies or products appearing in this document are trademarks and/or registered trademarks of their respective owners. Canon and CXDI are registered trademarks of Canon, Inc. in the United States and may also be registered trademarks or trademarks in other countries.